

## **Axial Flow Pump Type Ensival Moret CAHR**

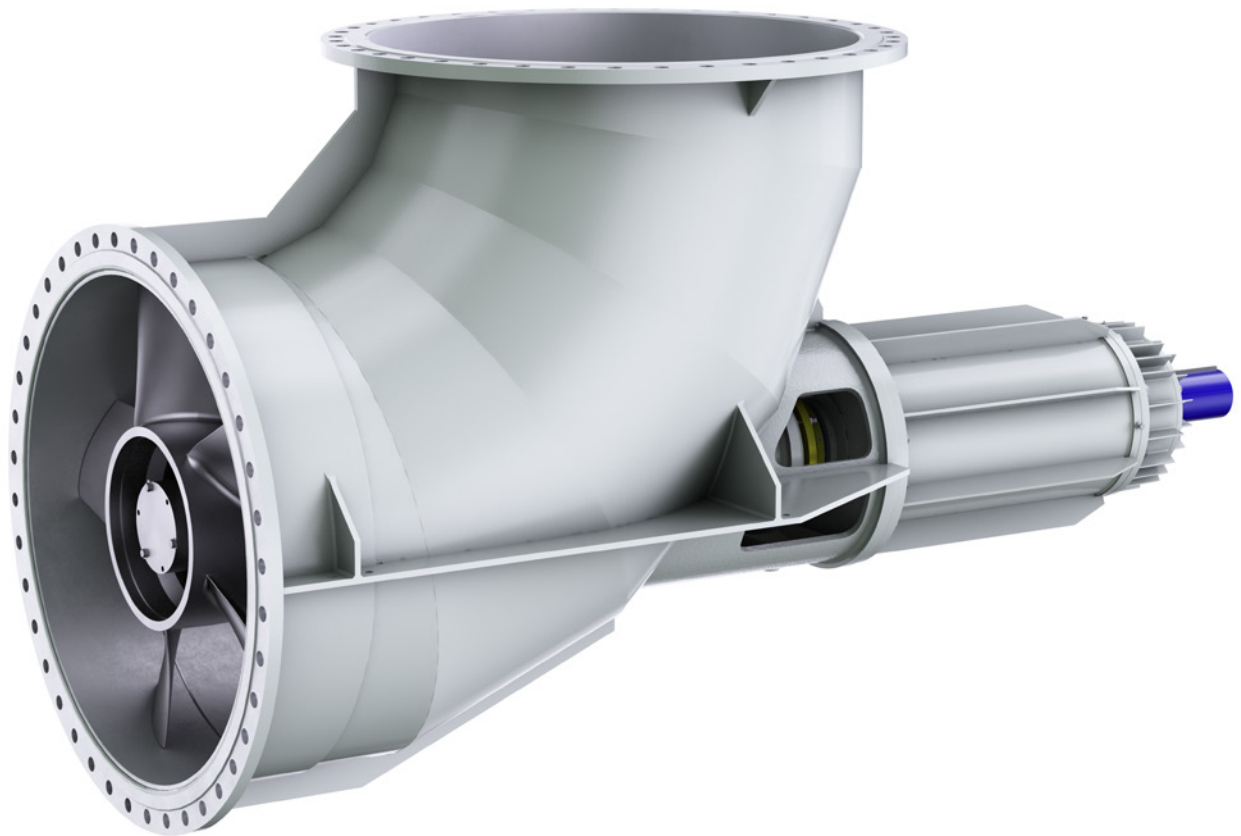

## Axial Flow Pump Type Ensival Moret CAHR

The CAHR pump range has been designed to handle both highly corrosive and abrasive liquids, as well as clear liquids and slurries in high-flow and low-head applications. With its heavy-duty construction and flexible design, the CAHR pump ensures maximum reliability and is perfectly suitable for all kinds of industrial processes.

### Features and Benefits

Sulzer's CAHR pump range has been designed using our long experience and in-depth knowledge of industrial processes. Optimized design combined with high-quality materials make the pumps more efficient and reliable while reducing maintenance costs. Key benefits include:

#### High efficiency

- Optimized hydraulics with innovative propeller profile provides high efficiency while reducing net positive suction head (NPSH)
- Precise selection among a wide range of hydraulics ensures a highly efficient process and perfect adaptability to process requirements.

#### Maximum reliability

- Heavy-duty design combined with high-resistance materials guarantee extended pump lifetime and low maintenance costs
- Highly reliable design due to strong shaft which reduces deflection and ensures long-term reliability of the shaft seal.

#### Easy installation and maintenance

- Maintenance friendly due to cartridge assembly with pre-assembled seal ensuring easy mounting and dismantling of shaft sealing
- Pre-assembled bearing with high radial and axial roller bearings guarantees easy assembly and maintenance and longer mean time between maintenance (MTBM).

#### High adaptability

- Cast or fabricated construction allowing manufacture from the smallest to the largest sizes of equipment while maintaining highest quality level
- High adaptability in all kinds of industrial processes due to flexible design with various configurations of installation.

## Heavy-Duty Design for Long Service Life in Severe Pumping Conditions

- 1 Flanges DIN or ANSI**
  - Other flange standards upon request
- 2 Discharge diameter from 200 to 1'800 mm (8 to 72 inches)**
- 3 Cast or fabricated design**
  - Offers high adaptability in all kinds of applications
- 4 Keyed impeller available in top or end suction configurations**
  - High efficiency over the entire performance range
- 5 Replaceable casing wear ring**
  - For extended lifetime of the pump
- 6 Optional enclosed shaft protected by a removable shaft sleeve**
- 7 Center line mounted pump casing**
- 8 No support bearing in the pumped liquid**
  - Suitable for heavy-duty slurry applications
- 9 Standard cartridge seal**
  - Gland packing, single or double mechanical seals available

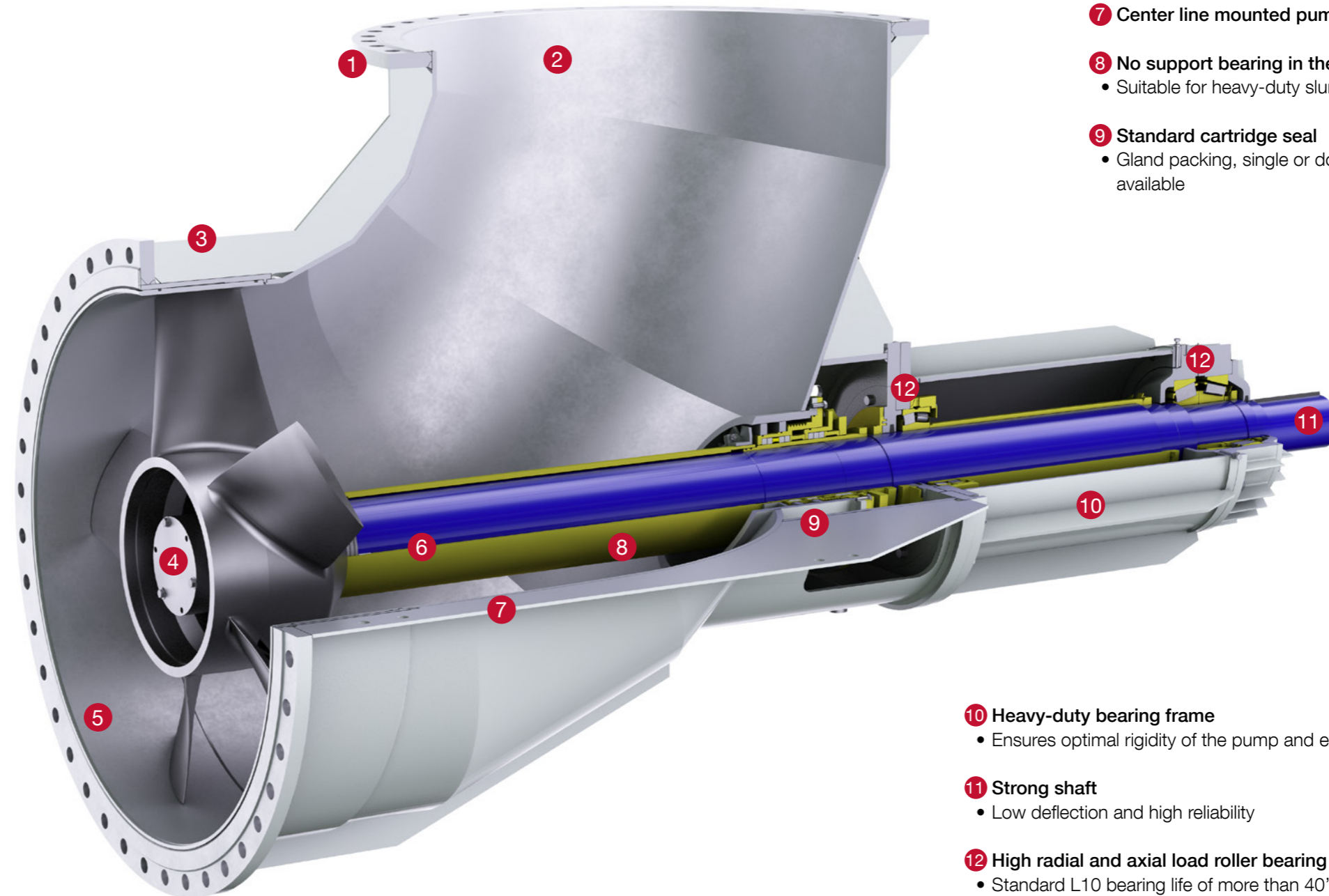

- 10 Heavy-duty bearing frame**
  - Ensures optimal rigidity of the pump and extended pump lifetime
- 11 Strong shaft**
  - Low deflection and high reliability
- 12 High radial and axial load roller bearing**
  - Standard L10 bearing life of more than 40'000 hours

## Construction Details

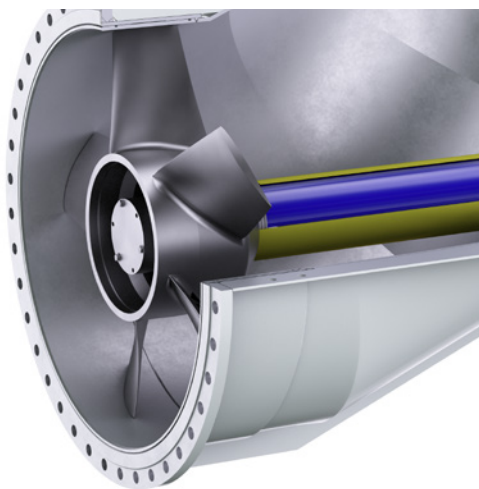

- Innovative propeller profile
- Optimized keyed impeller

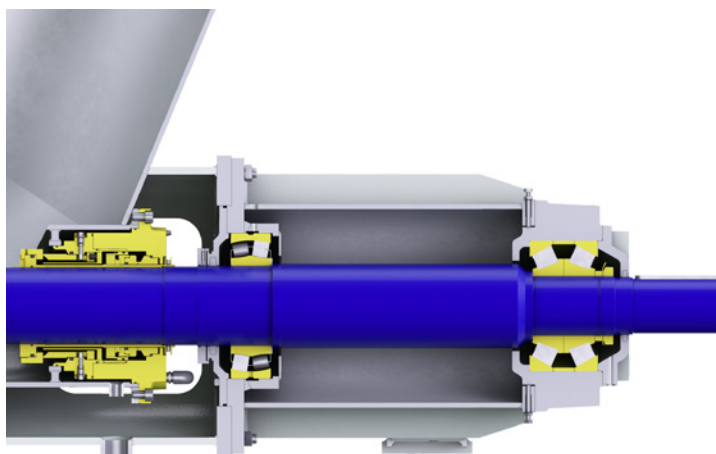

- Pre-assembled bearing for easy assembly and maintenance
- Strong shaft reduces deflection and ensures long-term reliability of shaft seal

## Materials

Sulzer offers specialist competence in corrosive, encrusting liquids and slurries, built on leading material technology. The CAHR pump range provides a wide range of high-quality materials for cast or fabricated designs, such as:

- Cast iron
- Austenitic stainless steel
- Duplex and Super Duplex alloys
- Titanium
- Other materials available upon request

## Shaft Seals

The shaft sealing system, exclusively mounted on a sleeve, ensures longer lifetime of the shaft and high reliability of the equipment. The cartridge assembly with a pre-assembled seal is standard and guarantees easy assembly and low maintenance costs. Types of shaft seals available:

- Soft packing
- Single mechanical seal
- Mechanical seal + soft packing
- Double mechanical seal
- Other types of shaft seals upon request

## Installation Schemes

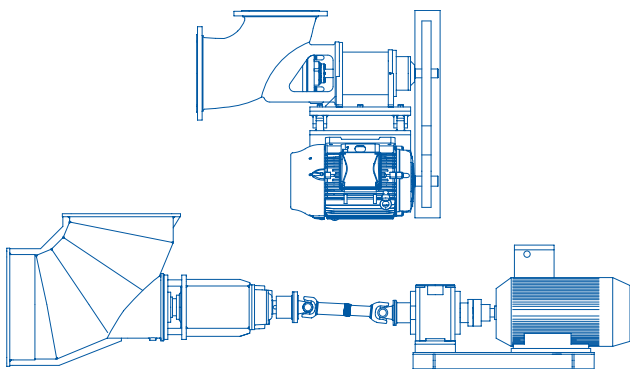

- Avoids the use of expansion joints and baseplate
- Required in case of a motor with high dimensions and weight

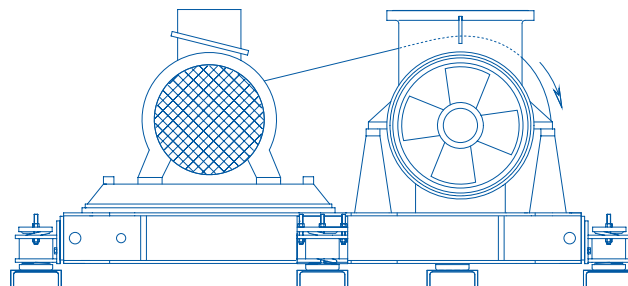

- Pump driven by V-belts
- Motor installed on slide rails
- Spring mounted baseplate avoids the use of expansion joints

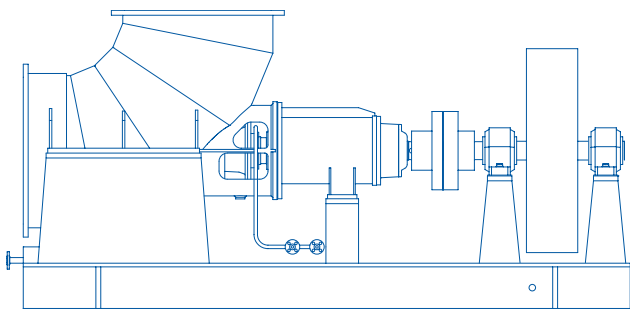

- Pump driven by V-belt transmission through a spacer coupling and intermediate shaft
- Motor installed on a support bracket with V-belt tensioning device
- Common baseplate for pump and motor

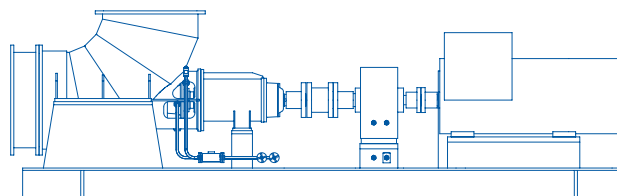

- Pump driven by gear box
- Required in case of a motor with higher power

## Vertical Design

The vertical CAHR-V pump range is mainly used as a forced feed circulator or closed loop under a vacuum circulator.

With its cantilever design, the CAHR-V pump has been specially designed to handle corrosive slurries in the following applications:

- Low-level flash cooler
- Phosacid slurry circulation



# Axial Flow Pump Type Ensival Moret CAHR



Oil and gas



Hydrocarbon processing



Power generation



Pulp, paper and board



General industry



Chemical process industry



Water and wastewater

## Operating data

50 Hz	Capacities	60 Hz
up to 40'000 m <sup>3</sup> /h		up to 176'000 USgpm
up to 8 m	Heads	up to 26 ft
up to 10 bar	Pressures	up to 145 psi
from -40°C to 180°C	Temperatures	from -202°F to 356°F

## Performance range

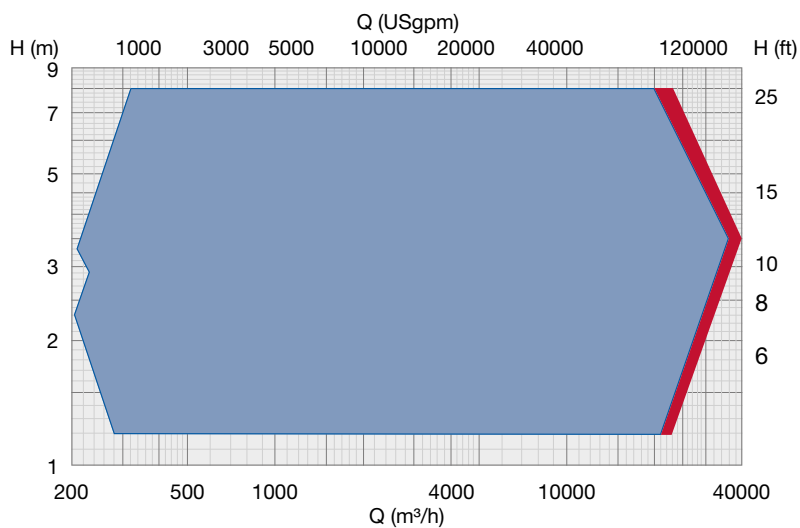



# We Do What We Say



## Operational Excellence

We continuously strive to be faster and better.



## Customer Partnership

Together, we win.



## Committed People

We build on the strengths and diversity of our people.

# A Global Specialist at Your Doorstep

Sulzer serves clients worldwide through a network of over 150 production and service sites and has a strong footprint in emerging markets.

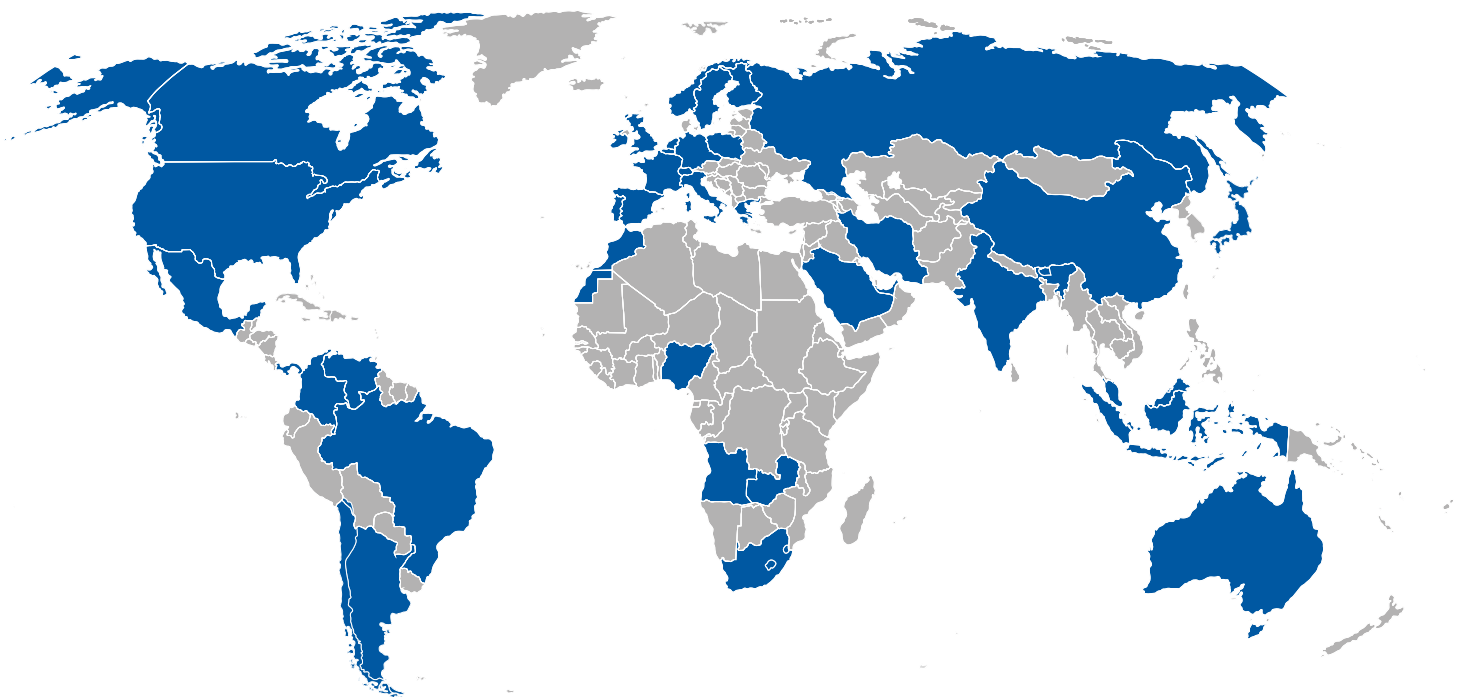



[www.sulzer.com](http://www.sulzer.com)

E10549 en 3.2018, Copyright © Sulzer Ltd 2018

This brochure is a general presentation. It does not provide any warranty or guarantee of any kind. Please, contact us for a description of the warranties and guarantees offered with our products. Directions for use and safety will be given separately. All information herein is subject to change without notice.